

# 1" DR. IMPACT WRENCH

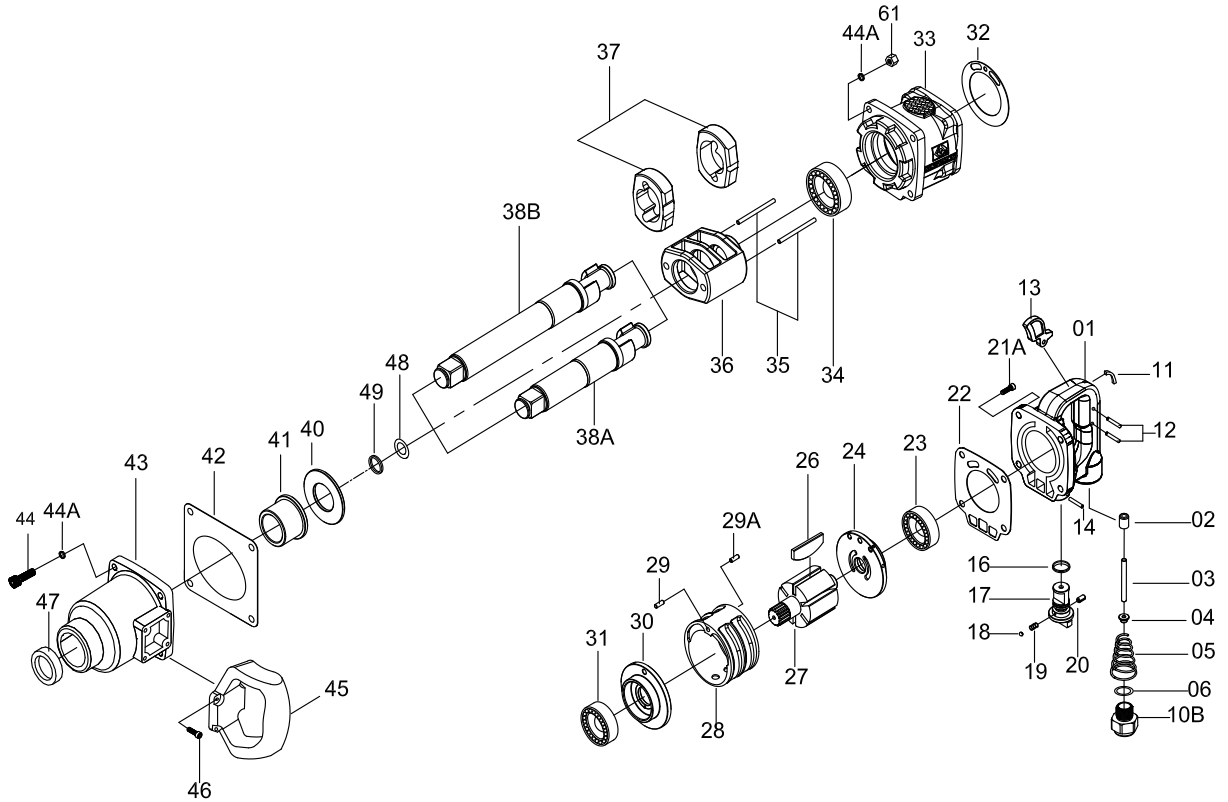

NO.33811-150  
33812-150



INDEX NO.	KT No.	DESCRIPTION	REQ'D NO.	INDEX NO.	KT No.	DESCRIPTION	REQ'D NO.
★ 1	033812-A01	Backhead Assembly ( incl. 2A )	1	32	033812-A32	Gasket	1
● 2A	033812-A02A	Throttle Valve Seat	1	★ 33	033812-A33	Housing Assembly	1
3	033812-A03	Throttle Valve Stem	1	34	033812-A34	Bearing	1
4	033812-A04	Throttle Valve	1	35	033812-A35	Hammer Pin	2
5	033812-A05	Spring	1	36	033812-A36	Hammer Frame	1
6	033812-A06	O-Ring	1	37	033812-A37	Hammer	2
10B	033812-A10B	Air Inlet	1	● 38A	033812-A38A	Standard Anvil ( for 33811-150 )	1
11	033812-A11	Rubber Cap	1	● 38B	033812-A38B	6" Extended Anvil ( for 33812-150 )	1
12	033812-A12	Pin	2	40	033812-A40	Washer	1
13	033812-A13	Trigger	1	41	033812-A41	Bushing	1
14	033812-A14	Pin	2	42	033812-A42	Gasket	1
16	033812-A06	O-Ring	1	43	033812-A43	Hammer Case	1
17	033812-A17	Reverse Valve	1	44	033812-A44	Screw	4
18	033812-A18	Steel Ball	1	44A	033812-A44A	Washer	8
19	033411-A14	Spring	1	45	033812-A45	Side Spade Handle	1
20	033812-A20	Pin	1	46	033621-B04	Screw	4
21A	033812-A21A	Screw	4	47	033812-A47	Oli Seal	1
22	033812-A22	Gasket	1	48	033812-A48	O-Ring	1
● 23	033812-A23	Bearing	1	49	033812-A49	Socket Retainer	1
★ 24	033812-A24	End Plate Assembly ( incl. 23 )	1	61	033812-A61	Nut	4
26	033812-A26	Rotor Blade	6	TK-01	033812-ATK1	End Plate Assembly ( incl. 23.24.29A )	
27	033812-A27	Rotor	1	TK-02	033812-ATK2	End Plate Assembly ( incl. 29.30.31 )	
28	033812-A28	Cylinder	1	TK-03	033812-ATK3	Standard Anvil Assembly ( incl. 38A.48.49 )	
29	033812-A29	Pin	1	TK-04	033812-ATK4	6" Extended Anvil Assembly ( incl. 38B.48.49 )	
29A	033812-A29A	Pin	1	TK-05	033812-ATK5	Hammer Case Assembly ( incl. 41.43.47 )	
★ 30	033812-A30	End Plate Assembly ( incl. 31 )	1	TK	033812-ATK	Tune-Up Kit ( incl. 5.6.16.18.19.22.26 ( 6 ) .32.42.48.49 )	
● 31	033812-A31	Bearing	1				

★ Must be purchased in assembly set

20131206R8

● Recommended not to be purchased alone due to assembly difficulty

**Air Pressure : 6.2 Bar (90 PSI)**

Inspec. Item No.	Square drive	Std. Bolt Size	Free Speed	MAX. Torque		Overall Length		Air Inlet	Air Hose	Avg. Air Consumption	Net Weight		Sound Pressure Level A-weighted	Sound Power Level A-weighted	Sound Pressure Valve Peak C-weighted	Vib. M/S <sup>2</sup>		
	inch	inch	mm	R.P.M	ft-lb	N.m	inch	mm	BSPT/NPT	ID	cfm	l/min	lbs	kgs				
33811-150	1	1-1/4	M36	4000	1500	2033	14-19/32	371	1/2" BSPT	3/4	9.0	255	22.71	10.30	101.17	112.16	102.00	10.77
33812-150	1	1-1/4	M36	4000	1500	2033	20-19/32	523	1/2" BSPT	3/4	9.0	255	24.91	11.30	100.40	111.40	101.00	6.13

