

3/4" DR. IMPACT WRENCH

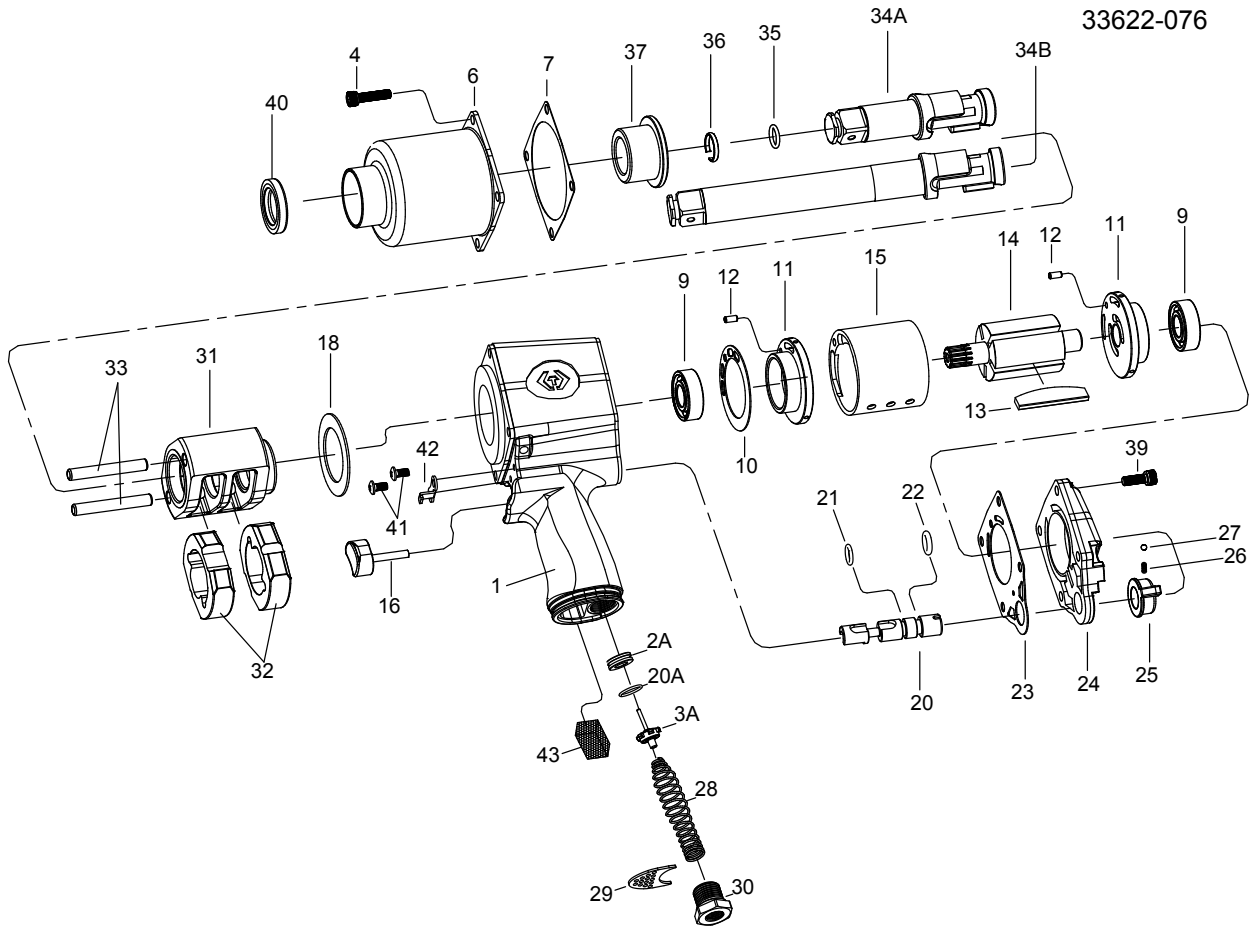

NO.33621-075
33621-076
33622-075
33622-076



INDEX NO.	KT No.	DESCRIPTION	REQ'D NO.	INDEX NO.	KT No.	DESCRIPTION	REQ'D NO.
★ 1	033621-B01	Housing Assembly (incl. 2A.20A)	1	27	033621-B27	Steel Ball	1
2A	033411-A02	Throttle Valve Seat	1	28	033411-A04	Spring	1
3A	033411-A03	Throttle Valve Assembly	1	29	033411-A05	Exhaust Deflector	1
4	033621-B04	Screw	4	30	033411-A06	Air Inlet (for 19 BSPT)	1
6	033621-B06	Hammer Case	1	30A	033411-A06A	Air Inlet (for 18 NPT)	1
7	033621-B07	Gasket	1	31	033621-B31	Hammer Frame	1
9	033621-B09	Bearing	2	32	033621-B32	Hammer	2
10	033621-B10	Gasket	1	33	033621-B33	Hammer Pin	2
11	033621-B11	End Plate	2	●34A	033621-B34	Standard Anvil (for 33621-075)	1
12	033621-B12	Pin	2	●34B	033621-B34A	6" Extended Anvil (for 33622-075)	1
13	033621-B13	Rotor Blade	5	35	033611-A45	O-Ring	1
14	033621-B14	Rotor	1	36	033611-A44	Socket Retainer	1
15	033621-B15	Cylinder	1	37	033621-B37	Bushing	1
★ 16	033621-B16	Trigger Assembly	1	39	033621-B39	Screw	4
18	033621-B18	Washer	1	40	033621-B40	Oil Seal	1
20	033621-B20	Reverse Valve	1	41	033621-B41	Screw	2
20A	033411-A20A	O-Ring	1	42	033621-B42	Trigger Retainer	1
21	033621-B21	O-Ring	1	43	033621-B43	Muffler Element	1
22	033621-B22	O-Ring	1	TK-01	033621-BTK1	End Plate Assembly(incl. 9.11.12)	
23	033621-B23	Gasket	1	TK-02	033621-BTK2	Standard Anvil Assembly(incl.34A.35.36)	
24	033621-B24	Backhead	1	TK-03	033621-BTK3	6" Extended Anvil Assembly(incl. 34B.35.36)	
25	033621-B25	Reverse Valve Knob	1	TK-04	033621-BTK4	Hammer Case Assembly (incl. 6.37.40)	
26	033621-B26	Spring	1	TK	033621-BTK	Tune-Up Kit (incl. 4 (4) .7.10.21.22.23.26.27)	

★ Must be purchased in assembly set

● Recommended not to be purchased alone due to assembly difficulty

20131206R6

Air Pressure : 6.2 Bar (90 PSI)

Inspec. Item No.	Square drive		Std. Bolt Size		Free Speed	MAX. Torque		Overall Length		Air Inlet	Air Hose	Avg. Air Consumption		Net Weight		Sound Pressure Level A-weighted	Sound Power Level A-weighted	Sound Pressure Valve Peak C-weighted	Vib. M/S ²
	inch	mm	inch	mm	R.P.M	ft-lb	N.m	inch	mm	BSPT/NPT	ID	cfm	l/min	lbs	kgs	dB(A)	dB(A)	dB(C)	M/S ²
33621-075	3/4		1	M24	6500	800	1085	8-63/64	228	1/4" BSPT	3/8	7.0	198	9.92	4.50	97.28	108.27	98.90	6.89
33621-076	3/4		1	M24	6500	800	1085	8-63/64	228	1/4" NPT	3/8	7.0	198	9.92	4.50	97.28	108.27	98.90	6.89
33622-075	3/4		1	M24	6500	800	1085	12-63/64	330	1/4" BSPT	3/8	7.0	198	11.02	5.00	96.68	107.68	97.80	6.46
33622-076	3/4		1	M24	6500	800	1085	12-63/64	330	1/4" NPT	3/8	7.0	198	11.02	5.00	96.68	107.68	97.80	6.46

