

1/2" DR. IMPACT WRENCH

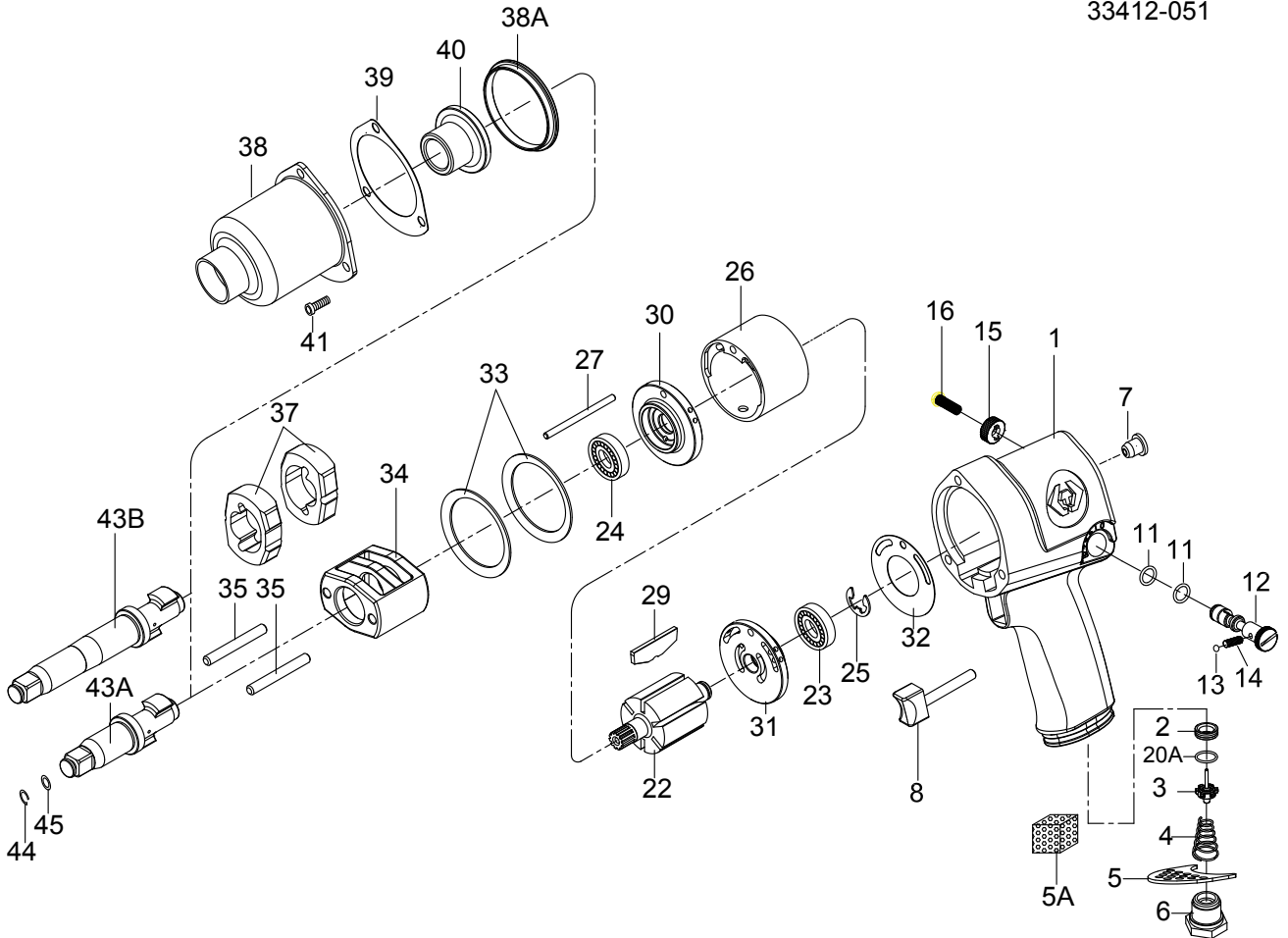

NO.33411-050
33411-051
33412-050
33412-051



INDEX NO.	KT No.	DESCRIPTION	REQ'D NO.	INDEX NO.	KT No.	DESCRIPTION	REQ'D NO.
★ 1	033411-B01	Housing Assembly (incl. 2.7.20A)	1	27	033411-B27	Cylinder Dowel	1
2	033411-A02	Throttle Valve Seat	1	29	033411-B29	Rotor Blade	6
3	033411-A03	Throttle Valve Assembly	1	30	033411-B30	End Plate	1
4	033411-A04	Spring	1	31	033411-B31	End Plate	1
5	033411-A05	Exhaust Deflector	1	32	033411-A32	Gasket	1
5A	033621-B43	Muffler Element	1	33	033411-A33	Motor Clamp Washer	2
6	033411-A06	Air Inlet (for 19 BSPT)	1	34	033411-B34	Hammer Frame	1
6A	033411-A06A	Air Inlet (for 18 NPT)	1	35	033411-A35	Hammer Pin	2
● 7	033411-A07	Grease Fitting	1	37	033411-A37	Hammer	2
★ 8	033411-A08	Trigger Assembly	1	38	033411-B38	Hammer Case	1
● 11	033411-B11	O-Ring	2	38A	033411-A38A	Hammer Case Pilot	1
12	033411-A12	Reverse Valve	1	39	033411-A39	Gasket	1
13	033411-A13	Steel Ball	1	40	033411-B40	Bushing	1
14	033411-A14	Spring	1	41	033411-A41	Screw	3
15	033411-A15	Reverse Valve Knob	1	● 43A	033411-B43A	Standard Anvil (for 33411-050)	1
16	033411-A16	Screw	1	● 43B	033411-B43B	2" Extended Anvil (for 33412-050)	1
20A	033411-A20A	O-Ring	1	44	033411-A44	Socket Retainer	1
22	033411-B22	Rotor	1	45	033411-A45	O-Ring	1
23	033411-A23	Bearing	1	TK-03	033411-BTK3	Standard Anvil Assembly(incl. 43A,44,45)	
24	033411-B24	Bearing	1	TK-04	033411-BTK4	2" Extended Anvil Assembly(incl. 43B,44,45)	
25	033411-A25	Retainer	1	TK-05	033411-BTK5	Hammer Case Assembly(incl. 38,40)	
26	033411-B26	Cylinder	1	TK	033411-BTK	Tune-Up Kit (incl. 3.4.11 (2) .25. 29 (6) .32.39.44.45)	

★ Must be purchased in assembly set

● Recommended not to be purchased alone due to assembly difficulty

20131206R6

Air Pressure : 6.2 Bar (90 PSI)

Inspec. Item No.	Square drive		Std. Bolt Size		Free Speed R.P.M	MAX. Torque		Overall Length		Air Inlet BSPT/NPT	Air Hose ID	Avg. Air Consumption		Net Weight		Sound Pressure Level A-weighted	Sound Power Level A-weighted	Sound Pressure Valve Peak C-weighted	Vib. M/S2
	inch	mm	inch	mm		ft-lb	N.m	inch	mm			cfm	l/min	lbs	kgs				
33411-050	1/2	3/4	M19	8000	650	881	7-41/64	194	1/4" BSPT	3/8	4.4	125	6.17	2.80	96.50	107.50	98.20	8.13	
33411-051	1/2	3/4	M19	8000	650	881	7-41/64	194	1/4" NPT	3/8	4.4	125	6.17	2.80	96.50	107.50	98.20	8.13	
33412-050	1/2	3/4	M19	8000	650	881	9-23/64	238	1/4" BSPT	3/8	4.4	125	7.05	3.20	96.19	107.18	93.10	6.84	
33412-051	1/2	3/4	M19	8000	650	881	9-23/64	238	1/4" NPT	3/8	4.4	125	7.05	3.20	96.19	107.18	93.10	6.84	

